



## RGB-MS-205, Mechanical Staging Gas Burner

### Specifications

- Mechanical staging burner with capacity of 490-2250 kW on gas side (49-225 Nm<sup>3</sup>/h for G20), and turn down ratio of 1:4, and NOx class II.
- Compatible with all types of combustion chambers according to EN-303 or BS-EN 12953 standards.
- Suitable for fire tube, fire box, water tube boilers, etc.
- The burner includes: mechanical components, burner head, flame tube, air fan, control panel, ignition devices, valves and all necessary safety devices in the gaseous fuel line.
- Burner controller: SIEMENS LFL or SHOKOUH/HONEYWELL TMG depends the policy of manufacturer based on the market availability or on the customer's order.

The controller includes: main controller, actuator.

- The gas train includes: filter, regulator, main and safety valve, pressure gauges, maximum pressure switch, minimum and leak test pressure switch, valve proving system (All according to BS-EN 676).

The recommended gas trains are offered in two types:

- Rp2 multi-block low-pressure gas train (inlet pressure of 93-360 mbar).
- Rp2 separate low-pressure gas train (inlet pressure of 107-360 mbar).
- If higher pressures are available, lower gas train sizes can be offered for better prices.

- Advantages: optimal design, high modulating ratio, silent operation, the ability to open from the hinge to both sides and ease of installation and maintenance.
- Optional ability: LPG fuel compatibility with LPG nozzle kits.

### More information

- Fan motor: 5.5 kW, 3 Phase, 380-400 Volt, 50 Hz, 2840 rpm.
- Operating ambient temperature: 5-60°C
- Maximum combustion air temperature: 60°C
- Noise emission level: 83 dB in 1.5-meter distance
- Casing insulation class: IP43
- Net weight: ~92 kg
- Packing dimensions (L x W x H): ~1350 x 860 x 750 mm

Reference conditions: Ambient temperature 20°C - Gas temperature 15°C  
- Barometric pressure 1013 mbar - Altitude 0 m (According to BS-EN 676)

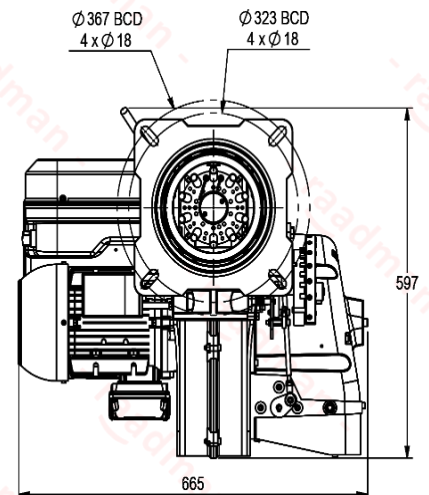
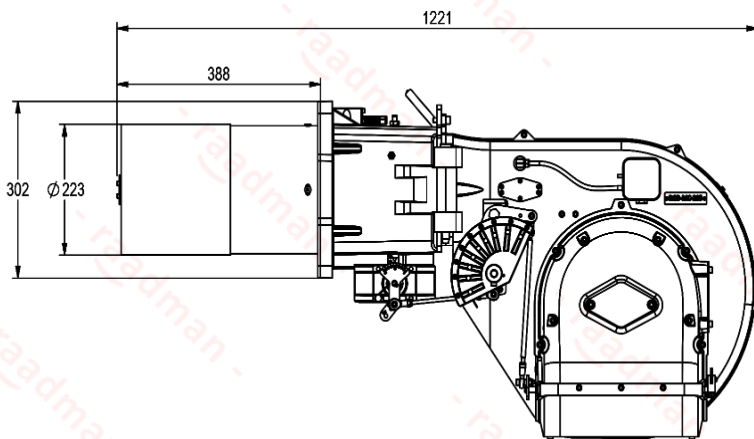
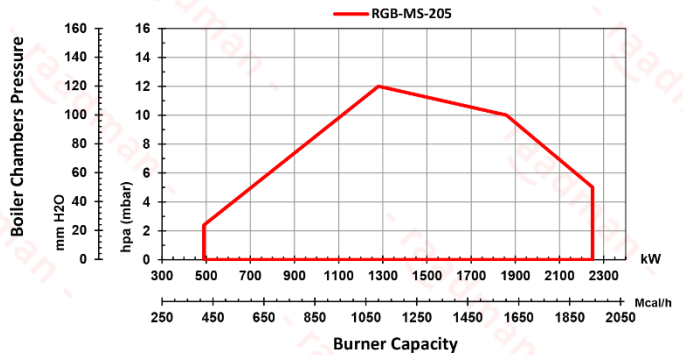

- Suggested boiler flange diameter = 235 mm

### Certifications

- Certified in EAEU countries standard No. 0378484.
- Certified in Iran national standard ISIRI-7595 (BS-EN 676).



Scan to access:  
Technical proposal  
Technical data  
Technical consultation  
Cad model (only for VIP customers)

